

ATTACHMENT 1-B

Please note:
The objective is to construct a fence that matches as closely as possible to the existing east and west fences at the job site. This spec should be used to get the basic concept of what we are looking for.

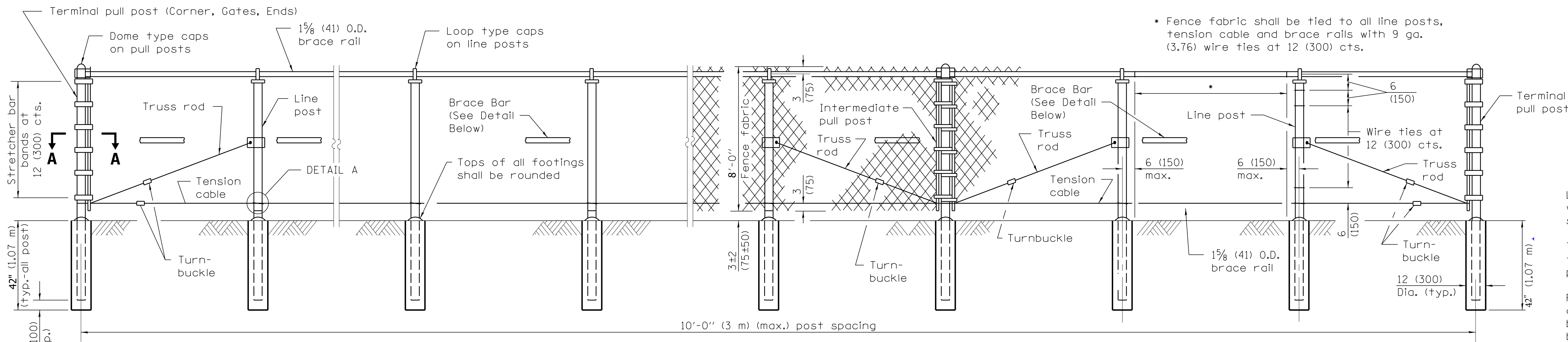

• Fence fabric shall be tied to all line posts, tension cable and brace rails with 9 ga. (3.76) wire ties at 12 (300) cts.

ELEVATION - (8') FENCE
 (Looking toward tree-line)

FENCE HEIGHT	POST SECTION (O.D.)	lbs./ft. (kg/m)
8'	*	*

Post sizes other than those shown may be used subject to approval by the Engineer.

- Line post - 2 1/2" OD Schedule 40, 3.65 lb/ft
- Terminal & Corner Post - 3" OD Schedule 40, 5.79 lb/ft

GENERAL NOTES

Loading for wind 80 mph (130 km/h) with 30% gust factor. Minimum allowable soil pressure = 1.25 tsf (120 kPa).

Tension cable shall be provided with one turn buckle between each pair of pull posts.

Pull posts shall be placed at locations determined by the Engineer. They shall be placed at 660' (200 m) intervals between posts to which the ends of the fabric are clamped or midway between such posts when the distance is less than 1320' (400 m) and greater than 660' (200 m).

X + Y shall not exceed 24 (600), 30 (750), or 36 (900), as applicable. When X is 0 - 9 (0 - 225), 15 (380), or 21 (525), then Y = 15 (375) and the post shall be shortened as required. When X exceeds 9 (225), 15 (380), or 21 (525), then Y shall be decreased correspondingly.

All dimensions are in inches (millimeters) unless otherwise shown.

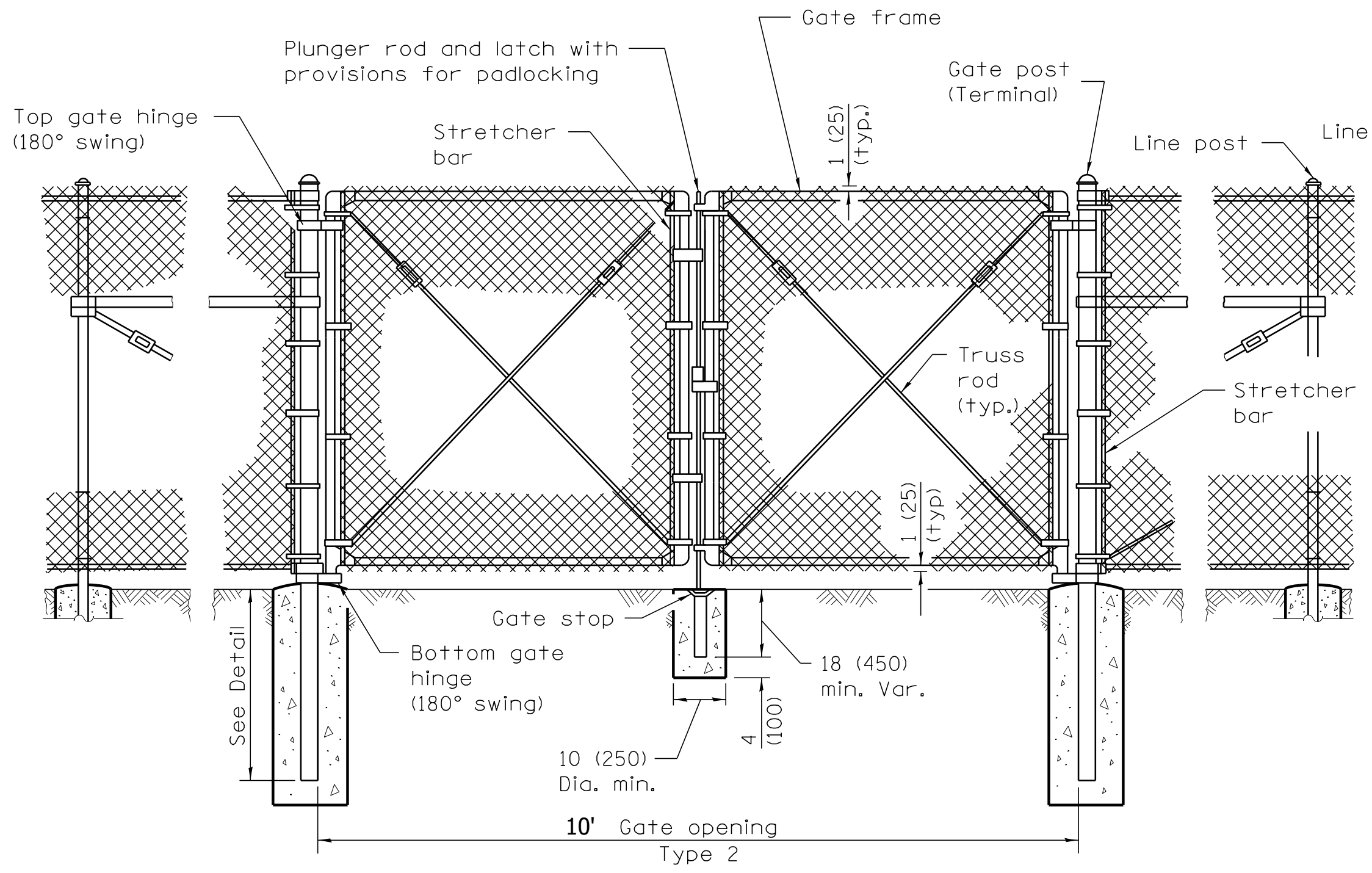

VEHICLE GATE ARRANGEMENT

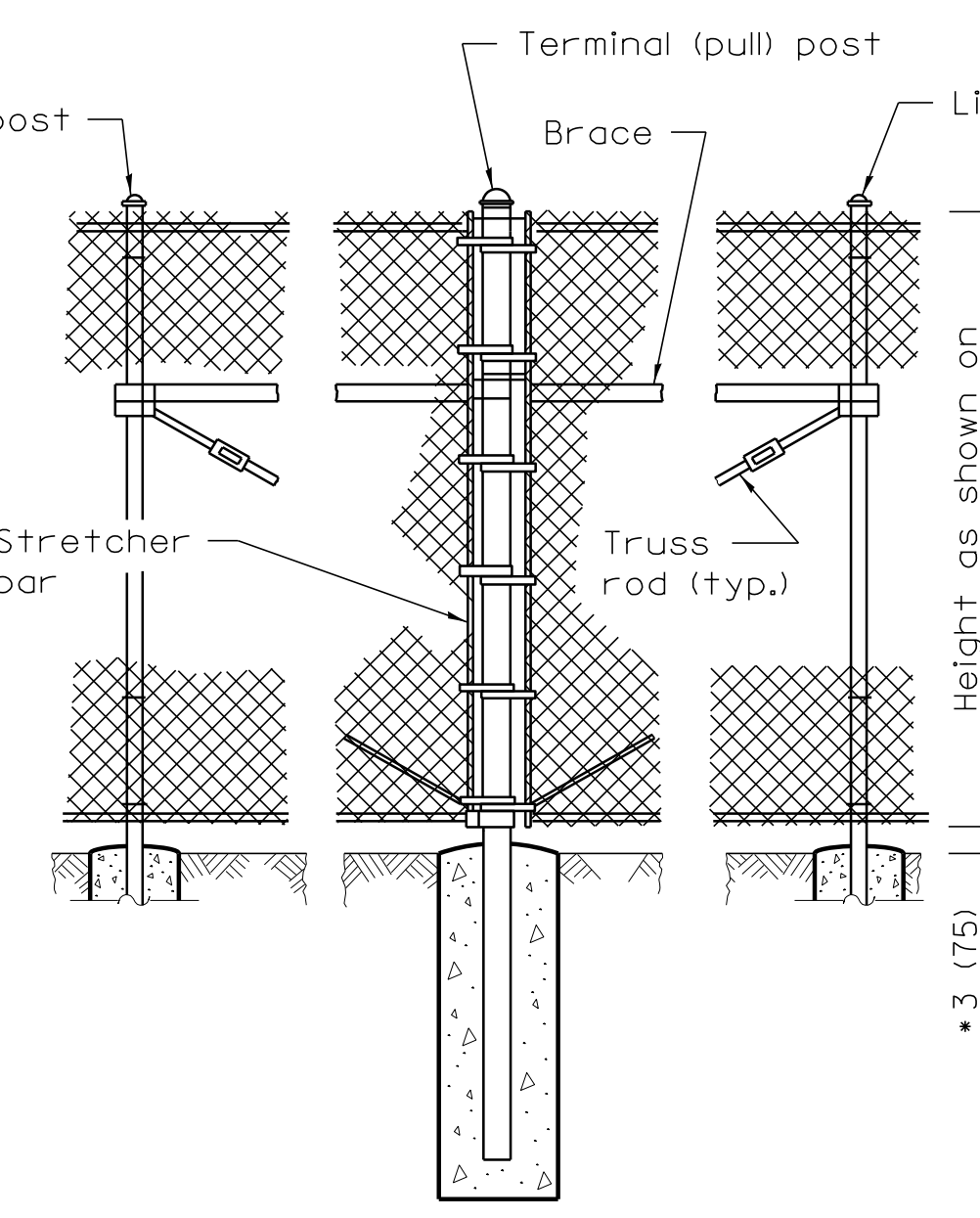

PULL POST ARRANGEMENT

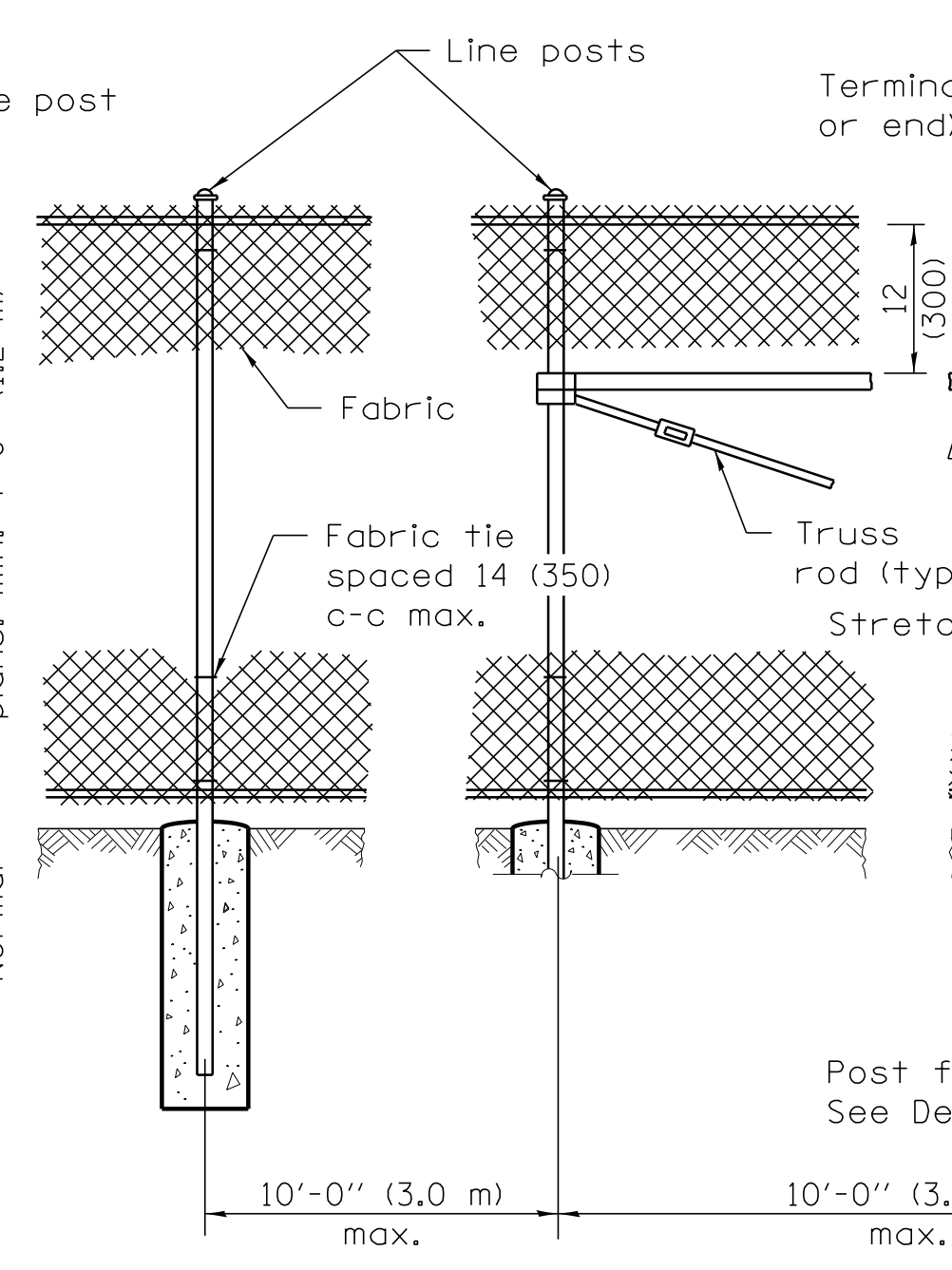

LINE POST ARRANGEMENT

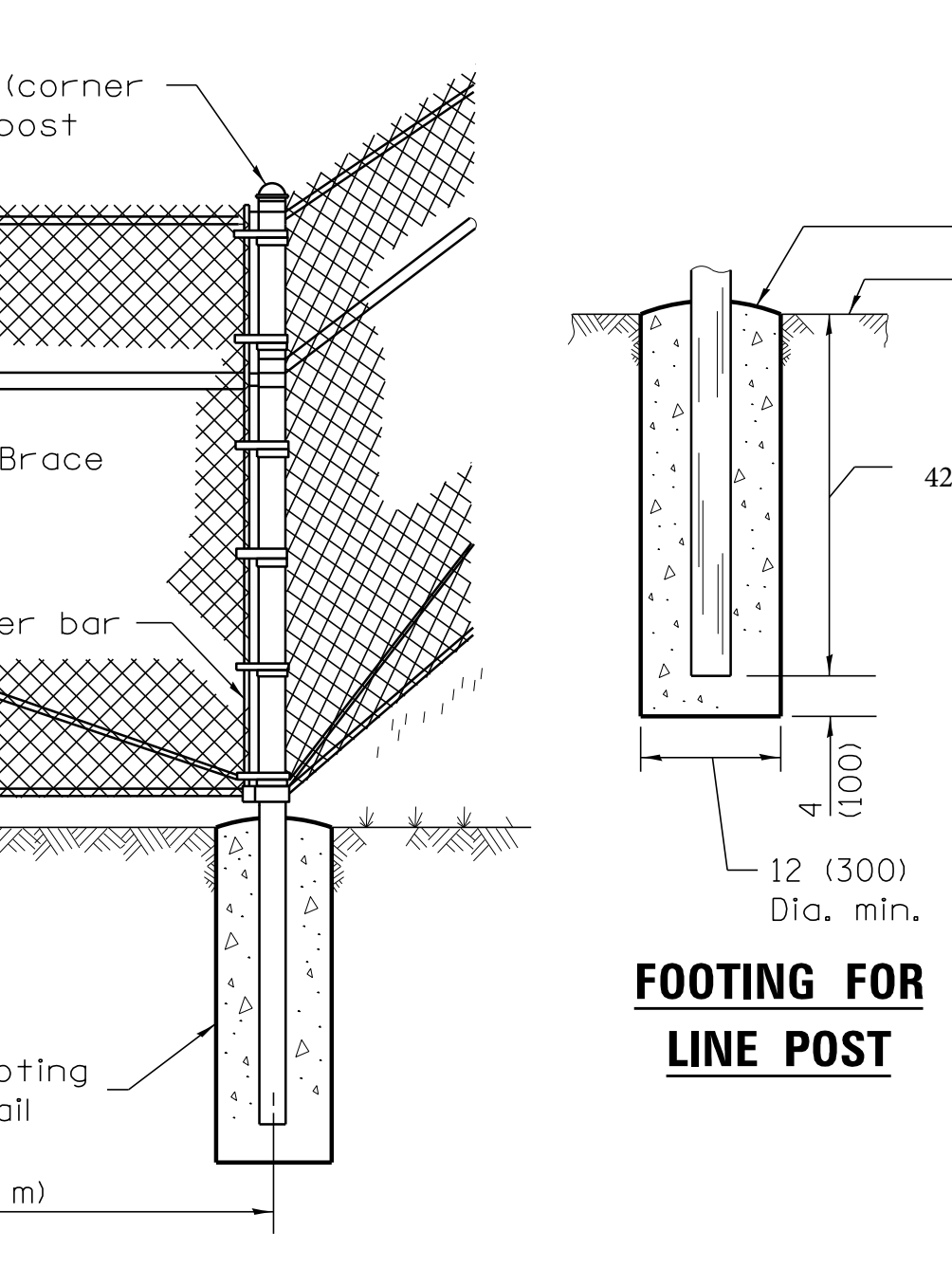

CORNER OR END POST ARRANGEMENT

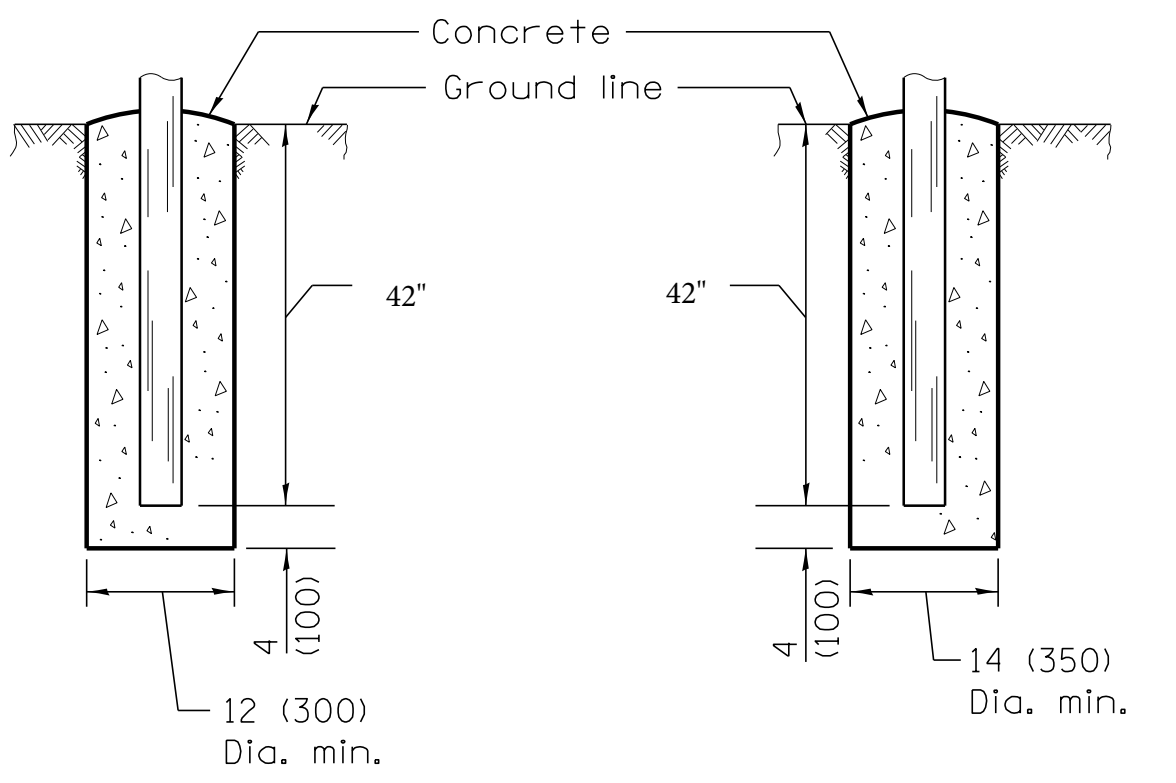

FOOTING FOR LINE POST

FOOTING FOR GATE & TERMINAL POST

FENCE, TYPE 2

CLIENT: LakeCounty Department of Public Works 650 West Winchester Road Libertyville, IL 60048	DSGN. DG DWN. KWB CHKD. DG SCALE: AS SHOWN PLOT DATE: CAD USER: NO. DATE FILE NAME	TITLE: LAKE COUNTY PUBLIC WORKS DES PLAINES RIVER WRF FENCING PROJ. NO. DATE: 11/7/2019 SHEET 1 DRAWING NO.
	FENCING DETAILS	